

MICHAELANASTASSIADES

INSTALLATION INSTRUCTIONS



REST, 2015

PRODUCT SPECIFICATIONS

Bulbs specifications 120V / 240V
G9 maximum wattage 40W
Provided with a 2500mm cord set and
dimmer switch.
Product weight: ~3kg

BEFORE INSTALLING

Please keep these instructions for future reference.

Please read instructions in full, noting illustrations, prior to installation and follow exactly.

The fitting is for use in a normal dry domestic indoor environment.

If you are in any doubt, consult a qualified electrician to install the fitting.

Ensure the circuit, to which the fitting is to be connected, has been installed and fused in accordance to national installation requirements.

Ensure that only the correct types of bulbs are fitted. Always switch off all the mains and allow the Lamp to cool before changing light bulbs.

Modifying any part of the light will void the products warranty.

Michael Anastassiades accepts no liability for incorrect use of the mentioned object.

CLEANING INSTRUCTIONS

Before cleaning, lighting fixtures must be turned off and unplugged from mains electricity. Whilst cleaning please take care and use the gloves provided.

Satin brass: Use the Scotch Brite pad (supplied in the product box) and gently rub the pad in the direction of the grain. Repeat until the natural patina is removed. If the Scotch Brite is not rubbed in the direction of the grain marks will occur. The colour of the product will temporarily get lighter until it re-oxidises.

Satin nickel: Use a lightly damp soft dust cloth and gently go over marks until clean. Dry it afterwards with a soft dust cloth. Make sure the product is completely dry before switching the electricity on.

Black patinated: Use a dry soft dust cloth and gently go over marks until clean.

Opaline glass: Remove the opaline glass from the product. Using a lightly damp cloth, clean only the outside of the sphere. Only put the glass sphere back on the product once it is fully dry.

Parts Supplied

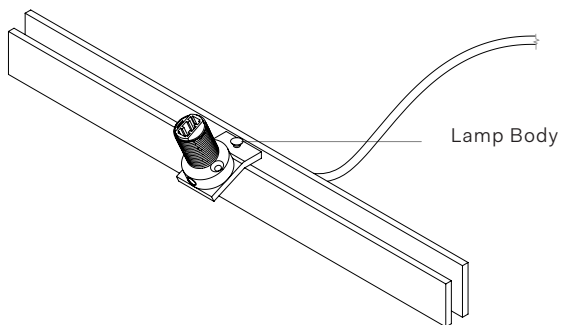
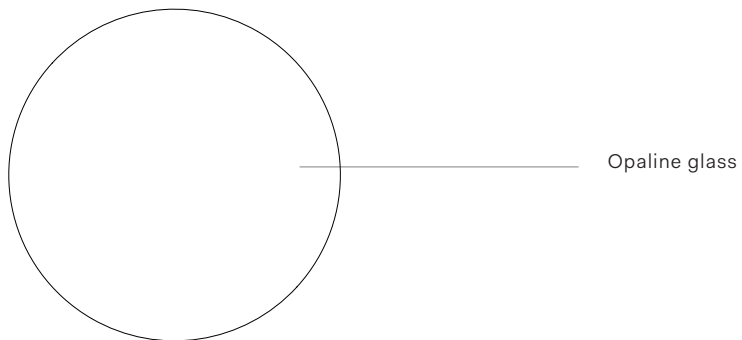

Additional Items Provided

Pair of Gloves
Spare Kit Bag

Fig. 1

Whilst installing the fixture please take care and use the white cotton gloves provided.

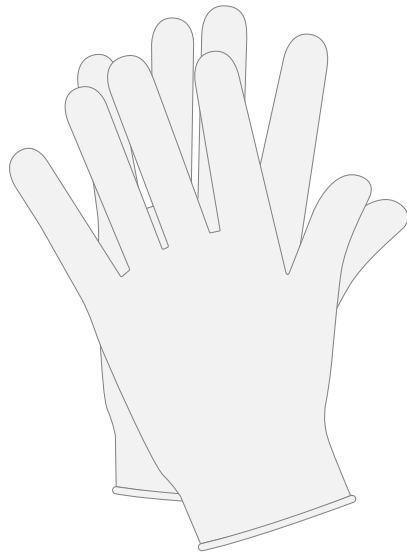
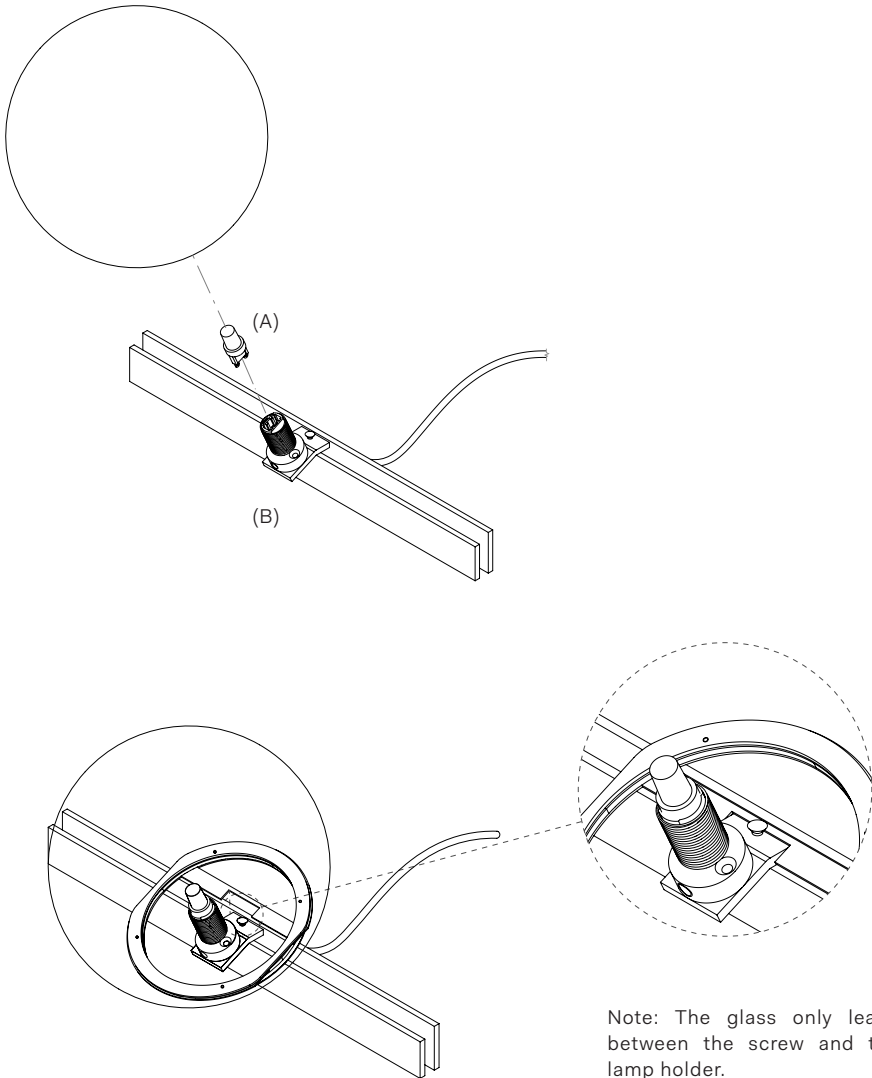

Fig. 2

Place the light bulb (A) provided into the bulb holder (B). Do not plug the light into the mains at this stage.



Note: The glass only leans between the screw and the lamp holder.

Fig. 3

To operate the lamp, use the inline dimmer as directed. Clicking quickly will turn the lamp on and off. Sustained pressure can be used to dim the light output.

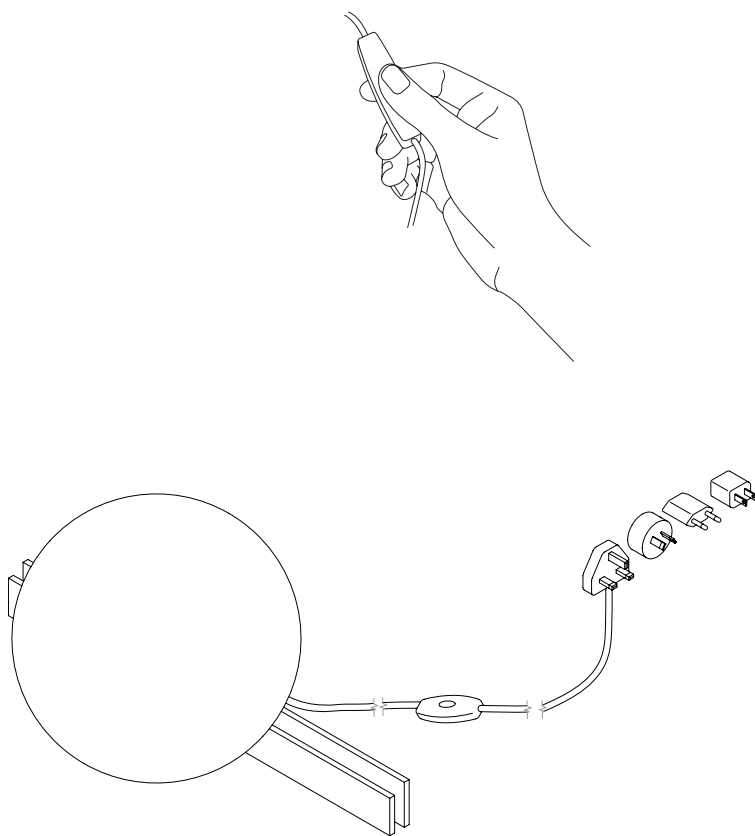

Michael Anastassiades' design philosophy is to preserve the inherent qualities of given materials. All of our products are handmade and come in natural finishes, exposed to the elements without any protective lacquers. We look at oxidisation as part of a process that adds to the patina of an object, increasing beauty with time. We try our best for all goods to leave our premises in pristine condition, but sometimes products may arrive with minor oxidisation marks.

Whilst every effort is made to ensure an accurate representation of product colours, finishes and dimensions, Michael Anastassiades Ltd reserves the right to alter these details without notice, in compliance with its own production needs, technological changes or in response to the current market needs. Colour swatches are for reference only; Michael Anastassiades Ltd cannot guarantee exact colour match for any product finishes.

All designs are protected under copyright law. Michael Anastassiades holds the exclusive manufacturing and distribution rights worldwide. Copying will be prosecuted.

All light fixtures in this catalogue have CE marking compliance.

Michael Anastassiades Ltd.
50 Rochester Place, London NW1 9JX
T +44 (0)20 7928 7527
sales@michaelanastassiades.com
www.michaelanastassiades.com
© 2020 Michael Anastassiades Ltd. All rights reserved.